

600 W LED profile moving head light(Framing light)

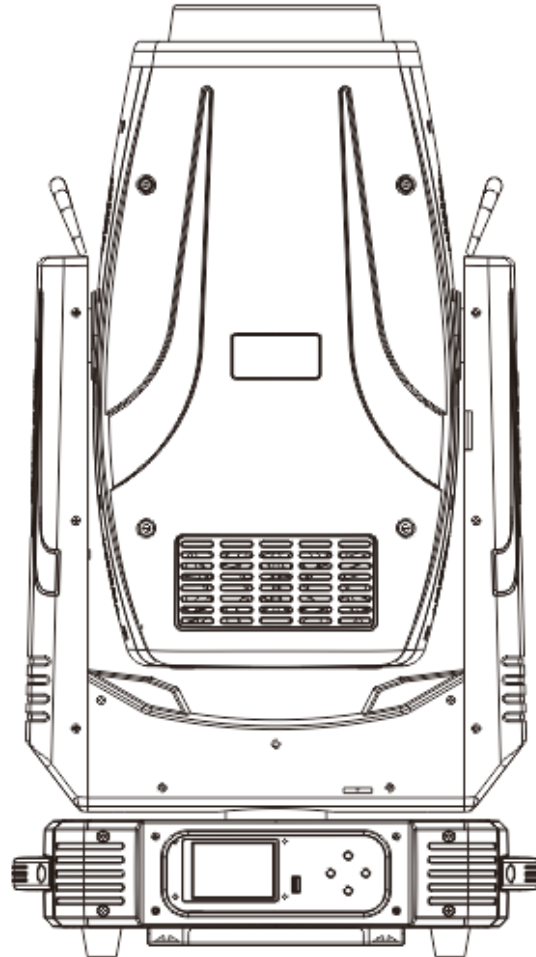

Net Weight: 32KG

POWER: 700W

Color Temperature: 2800-5600K

ITEM

Item	02
1.Product introduce	03
2.Fixture size	03
3.Parts introduce	04
4.Description of color wheel and GOBO wheel	04
5.Safety information	04
6.Packing and shipping	08
7.Installation standard	09
8.AC power	09
9.LED lamp model and replace	10
10.Warranty period for special accessories	11
11.PCB Driving board	12
12.Control panel operation menu	12
13.DMX Channels	16
14.Routine maintenance	19

STATEMENT

The product is good packing when ship out the factory. All users should strictly abide by the warnings and instructions stated in this manual, any damage and results due to misuse and the neglect of this operating manual will be excluded from the deal responsibility this manual will not informed in additionally if have technical changes.

1. PRODUCTION INTRODUCE

Thank you for choosing this product. This is our latest development of intelligent, efficient products, beautiful and fluent, combined with the advanced technology of the stage lighting today. It has advanced international electronic control technology and excellent human nature chemical industry. The product is fully in conformity with the CE standard and the recipient country. The standard DMX512 signal mode is supported by the RDM protocol. Production enforce standard IEC 60598-1:2014, IEC60598-2-17:2017.

Channels mode: 16/24CH;

Lamp: 600W White LED Engine ;

Life time: 20000 hours;

Light Source Luminous Flux: 30000;

power: AC110-240V,50/60Hz;

Total power: 700W;

Display: 2.8 inch screen display, canreverse 180° ;

Color wheel: 7 fix colors+white+CMY+CTO.CT:2800-5600K

Fixed gobo : 8 gobo + white.

Rotation gobo: 6 gobo+ white,changeable;

Prism: 4 facet prism ,Frost function;

Beam angel : 6~42° ;

Dimmer : 0-100% linear adjustment ;

Iris: Disphragm adjustable

Cut: 4 plates.Aftercut,the pattern canrotation 180°

connector can set dmx address with powerand upgrade the software.

Position lock system: Magnetism positionlock system

Pan : 540° ; 8Bit/16Bit ;

Tilt : 270° ; 8Bit/16Bit ;

IP Rate: IP20;

2. FIXTURE SIZE

Product size: 404 (L) × 306 (W) × 736 (H) mm

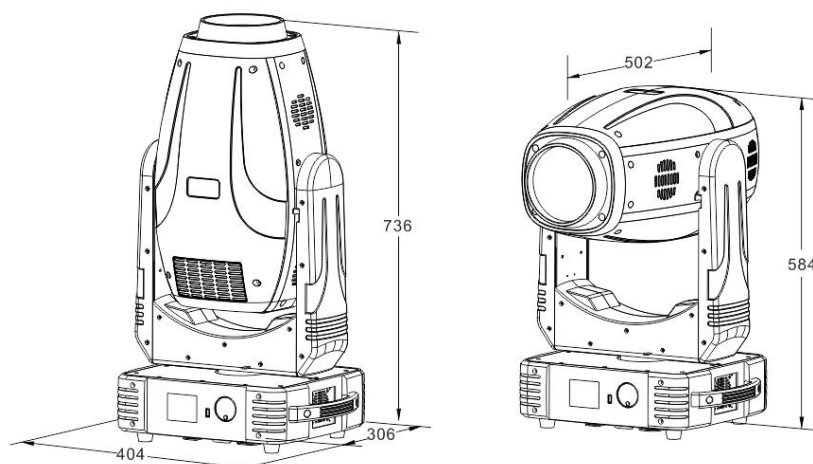

3. PARTS INTRODUCE

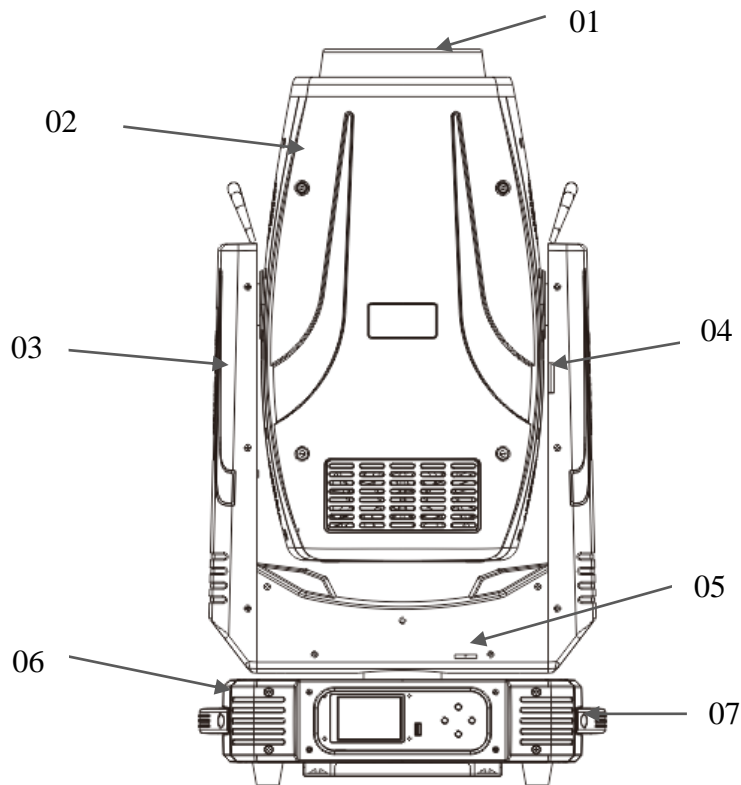

- 01 — Lens
- 02 — Body
- 03 — Arm
- 04 — Tilt Lock
- 05 — Pan Lock
- 06 — Light base
- 07 — Handle

The structure of each part of the product is marked, and the main components of the lamps and lanterns are made up of the product names, so as to further understand the lamps and lanterns products.

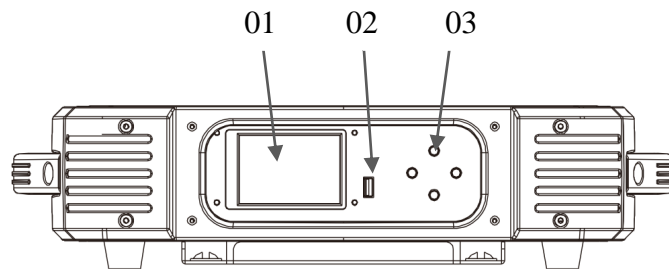

- 01 — Control panel
- 02 — USB Port
- 03 — Button

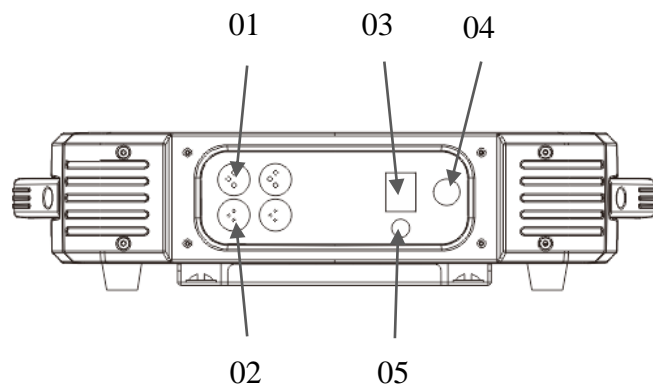

- 01 — DMX In
- 02 — DMX Out
- 03 — Power switch
- 04 — Power in
- 05 — Fuse

The function of the product panel is introduced, the name of the part on the panel is indicated, and

the functions and functions of each part are familiar.

4. A description of a color wheel, a BOBO wheel, and so on

Color wheel: 7 fix color +white+CMY+CTO. CT:2800-5600K

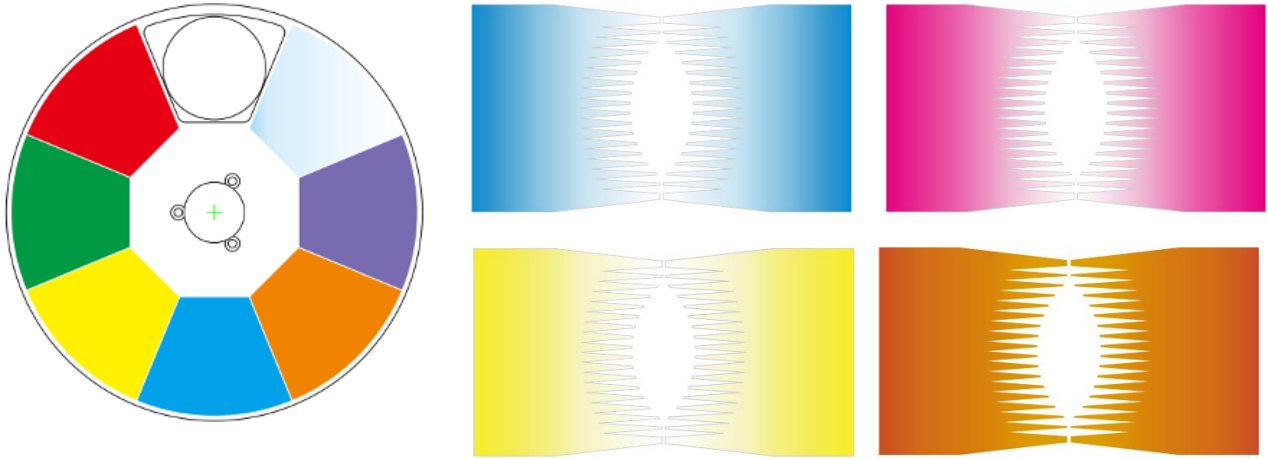

Fixed GOBO : 8 GOBO + white.Rich design, with the four prism better effect;

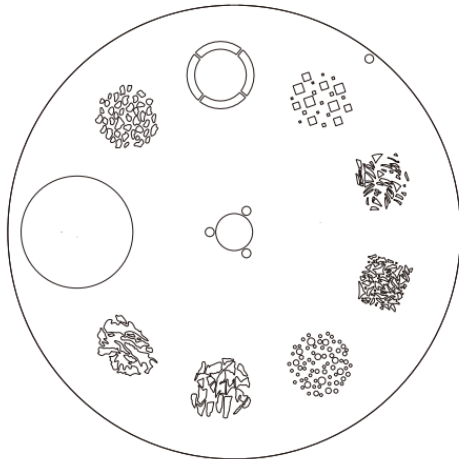

Rotation GOBO: 6 GOBO+ white.The rotation of the GOBO is smooth and the changeable is convenient.

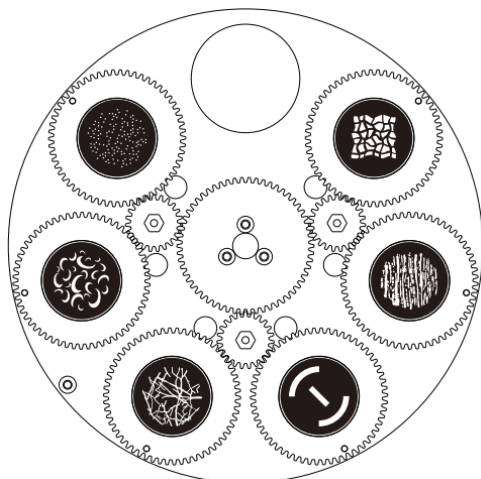

Equipped with a four prism, positive and negative rotation; linear atomization function;The prism with focused, rotated, enlarged and jitter, and the rotation speed can be adjusted.

4. SAFETY INFORMATION

5.1.1 SAFETY WARNING MESSAGE



1、 This product is only suitable for professional use, and does not apply to security for other purposes.

After you got the lights, please check the package whether have any damage caused by transportation. If there is any damage, do not use this fixture, and please contact the dealer or manufacturer as soon as possible.

2、 This product is only suitable for indoor, IP20 protection class. Lamps should be kept dry to avoid Moisture, overheating or dusty environment. Prevent lamps come into contact with water or any other liquid.The use of this product should pay attention to: fire, heat, electric shock, ultraviolet radiation, the lamp to explode or shedding caused serious or fatal injury.

5.1.2 NEED TO READ THE INSTRUCTIONS BEFORE USE ENERGIZED OR



INSTALLING

1、 Follow through the operation of security methods and pay attention to the warning signs on the specification and equipment.

2、 If you have any problem for how to safely operate the equipment. Please contact your dealer.



5.1.3 OPERATION IS PROHIBITED

The above symbol specifies that the unit in automatic mode. Manual operation is prohibited. Do not manually force the equipment or its elements.



5.1.4 POINTING IS PROHIBITED

Never point the lights directly to the sun or other strong light source.

5.2 TO PREVENT FALLING WOUNDING



- 1、 Please don't move the package by one person only.
- 2、 When Hang the fixture, please must verify that the facilities to be able to withstand the weight of the lamps at least 10 times more.
- 3、 Please make sure the Mounting hardware is strong enough no any damage, and insurance for the safety rope as auxiliary security fixed in other facilities will need to verify before installation. Installing or removing the equipment, to make the pulley below the work location.

5.3 UA PROTECTION AND THE BULB EXPLOSION



- 1、 Prohibit straight viewpoint with exposed bulbs to avoid UV damage to the eyes;
- 2、 Do not use the equipment without the lens screen and the lid;

The lens and the light head covers should be timely replaced if any damage to rupture

- 3、 The Fixture should be used with the protection screen together.

5.4.1 ANTI-HIGH TEMPERATURE (Rated maximum ambient temperature)

$t_a = 40^{\circ}\text{C}$

Please don't use the equipment if the temperature above 40°C .

5.4.2 ANTI-HIGH TEMPERATURE (Maximum outer surface temperature)



$t_c = 110^{\circ}\text{C}$

When the luminaire reaches the state of thermal stability, the maximum temperature on the external surface can reach 110 degrees. Please do not touch the lamp body when the luminaire is working.



5.5 IP PROTECTION

The product are certified at IP 20 levels only. Adequate additional protection should be taken for outdoor use. All lamps, lights and their fittings should be kept dry. Overheating dust and excessive humidity must be avoided.

5.6 BURST PREVENTION

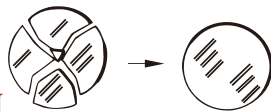

- 1、 The lens should be changed if had damaged or any problems.
- 2、 Don't change the non-original manufacturer len
- 3、 Len size: $\varnothing 168*52\text{mm}$.

5.7 PREVENTION OF ELECTIC SHOCK



- 1、 The electrical connection must only be carried out with corresponding qualifications;
- 2、 Before installing, make sure you use the power voltage lamps must comply with the identified power, voltage and have an overload or leakage protection;
- 3、 Each lamp must be properly grounded, installed in accordance with the relevant standards;
- 4、 Cut off the power when stall or replace the lamp and the fuse;

5、 Prohibit the use of a lightning storm or wet environment.



5.8 MAINTENANCE

Before starting any maintenance work or cleaning the projector, cut off power from the mains supply. After switching off, any part of the luminaire can not be disassembled within 10 minutes in order to avoid burns. If you need to replace the bulb, you have to wait 20 minutes to avoid burns.

5.9 TO PREVENT BUTNING OR FINE



- 1、 Please do not install lamps directly on the surface of ordinary combustible materials.
- 2、 Do not short-circuit temperature protection switch or fuse, use the specified type of fuse.
- 3、 The equipment must be installed away from flammable and explosive materials. The shortest distance between the equipment and the flammable material is 3M.
- 4、 The equipment should be projected range of 15 meters away objects and projectiles temperature less than 60 ° C.
- 5、 Fan or ventilation, at least in the range of 0.5 meters can not be an obstacle.
- 6、 Do not place any object on the lens.
- 7、 Handling at least allow the device to cool for 20 minutes.
- 8、 Do not use non - original accessories.

6. PACKAGE

packed with fly-case of two in one ,or carton .Attach follow accessory

6.1 ACCESSORY

CONTENT	QUANTITY
USER MANUL	1
SIGNAL CABLE	1
Safety Steels(Selection)	1
Clamps(Selection)	2
drawbridge	2

6.2 TRANSPORT PROTECT LOCK

In order to protect the light, there is a protect lock; During the transport , the lock catch position need lock in the center, and the fixture keep in vertical state.

6.3 ABOUT PACKING



1. Before packed, make sure power is off, and wait for at least 20mins for cooling down.
2. Before clean the fixture, make sure X, Y axis protect lock closed.
3. After packed by plastic bag, high-lift the fixture with two handles besides the product. put the product into the fly-case up-side-down.

4. After packed the product, put the accessory into the accessory case, then closed and lock the fly-case.

5. Fly-case only up stacked two layers. Prohibited upside down

6. When packed with carton box, equipment should be put into the foam first, then set into a carton, pay attention to the vertical position.

6.4 UNPACKING

Note: Before unpacking check the damage is whether due to the transportation or not, if you find any such damage, please do not use this item, and contact with the dealer or manufacturer as soon as possible.

1. Open the fly-case, and discover the inside plastic bag.
2. High-lift the product by two handles beside the bottom base and move it out.
3. Before power on, make sure you have opened the X, Y axis lock!

7. INSTALLATION STANDARD

7.1 INSTALLATION OF THE RIGGING

The product can be placed on the stage or mounted on any supporting frame. The quick locking system can quickly and easily press 2 directions to lock on the bracket.

7.2 EQUIPMENT FIXATION

1. Before installation, it is necessary to verify that the gear clamp is not damaged and can bear at least 10 times the weight of the equipment. The verification building can bear the weight of at least 10 times the total weight of the equipment and fixture cable attached equipment.
2. The fixture is mounted on the base of the lamp body, inserts the fastener into the mounting hole of the base, and holds the handle of the fastener to lock the 1/4 ring clockwise, and the other fasteners are installed in the same way.
3. Install a safety rope that can withstand 10 times the weight of the equipment.
4. Check whether the vertical lock has been opened. There is no combustible or attached in the verification equipment within 3 meters. Near other flammable objects.



Attention!

Must use two clamps fix the fixture, and tighten the clamps with 1/4 lock, only fully clockwise rotate 90 ° then can lock the fasteners. Add one safety insurance rope on the hole of light base. pls attention not connect to the transport handle.

7.3 DEVICE CONNECTION

Attention!



- 1、 One product only can accept one input one output.
- 2、 The input is a DMX. The output is by means of a 3 core socket as follows.
Pin 1: +ve polarity signal
Pin2; -ve polarity signal
Pin3: Grounded.
- 3、 DMX512 cable must use the professional shielded twisted pair cable; standard loudspeaker cable is not reliable to control the long-range data.24AWG cable is suitable for more than 300 meters long-distance signal transmission and must add DMX 512 signal amplifier.
- 4、 Do not use two outputs to separate the connection, if separate a continuous connection to branch, DMX512 splitter is necessary.If use the DMX512 splitter. At first connect DMX512 Splitter input terminal to controller .And then connected from the splitter output terminal to next device.Do as above guide to connect other device, and finally coupled with terminal insertion.

8. AC POWER

9. 8.1 VOLTAGE, POWER, FUSE SPECIFICATION

Input Voltage	Total Power	Frequency
110-240V	700W	50/60HZ

Fuse voltage	Electronic current	Specification
250V	10A	5×20

8.2 POWER PROTECT

The equipment must be operated by professionals; Make sure that the voltage of power supply must be comply with the voltage identified on the lamp, and must have an overload or leakage electrical protection.

ATTENTION !



Factory has equipped the standard 3 pin plug socket. Connect the power supply as below table. If lamp cable is damaged, replacement should be operate by factory or qualified staff. Any question, please contact professionals or talk to a qualified electrician.

Live wire (L)	Null (N)	Ground wire	
BROWN	BLUE	Yellow +Green	

9 . LED LAMP MODEL AND REPLACE

9.1 LED LAMP DESCRIPTION

LED LAMP MODEL	POWER OF LAMP	LIFE/HOUR	Lumen
UNIONLUX 470W	500w	20000 HOURS	30000Lux

9.2 LED LAMP REPLACE



9.2.1 The light source of this luminaire is a non user replacement light source. If it is broken, please replace it by the manufacturer or its agent service provider or a qualified person.

10. Warranty period for special accessories

10.1 LED drive have a 1 year warrantee.

10. 2 The warranty period of power supply and electronic circuit board is 3 years.

11. CONTROL PANEL

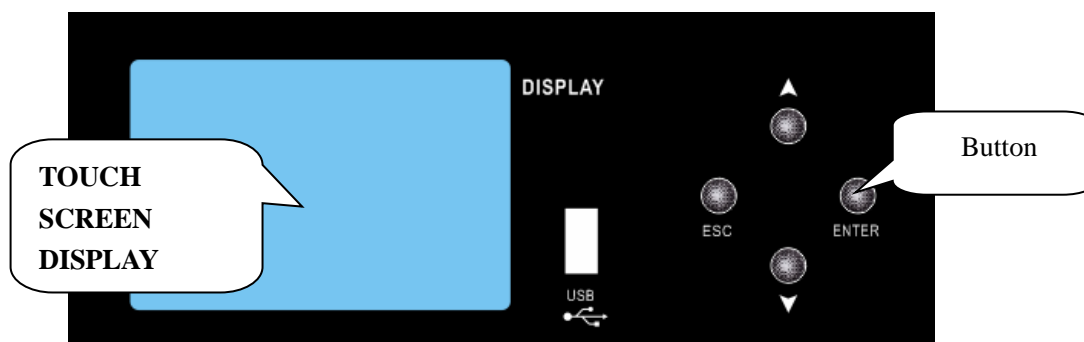

The control panel has a user friendly touch screen to display the operation data and other information.

There are four buttons on the right side.

Each button has a dedicate function.

Top button is for upward movement , lower button is for downward movement. The left button is for exiting the selected function where the right button in for confirming the function or data.

12. CONTROL PANEL MENU OPERATE

Main Menu	Submenu 1	Submenu2	Function SET	Function description
	<<			to address 1
	<			Address +1
	>			Address-1
	<<			001-512
DMX ADDRESS			SAVE	save and back
			ESC	ESC
			DMX	DMX
			Wire	not active
FEATURES SETTING	Run Mode:		Aoto	not active
			37CH	37CH model
	Channel Mode:		41CH	41CH model
			Off	Pan Scan Normal
	Pan Reverse:		On	Pan Scan Reverse
			Off	Tilt Scan Normal
	Tilt Reverse:		On	Tilt Scan Reverse
			Off	Pan/Tilt optical sensor testing off
	Opto Check:		On	Pan/Tilt optical sensor testing on
			Noml	Pan/Tilt Scan Speed setting normal
	PT Speed:		Slow	Pan/Tilt Scan Speed setting slow
			Fast	Pan/Tilt Scan Speed setting fast
			Off	keep signal data
	Singl Clear:		On	clear signal data
			Off	half color function
	Full Colour:		On	full color function
Off			Shortcut off for colors and gobos	
ShortCut:		On	Shortcut open for colors and gobos	
		ADV.	(ADVANCED FUNCTION)	
			RST.	Re-setting and back

back

		SAVE	Save and back	
		ESC	Back	
ADVANCED FUNCTION	Redress	ZEROSETTING		
		Pan rotation	0-255	Adjust the begging state
		Tilt rotation		
		focus		
		zoom		
		Cyan+blue		
		Magenta		
		Yellow		
		Color temperature		
		Color wheel		
		Dimming		
		aperture		
		Fixed GOBO		
		Rotate GOBO		
		GOBO Rota		
		Prism		
		Prism Rota		
		FROST		
		Blade up 1		
		Blade up 2		
		Blade down 1		
		Blade up 2		
		Blade right 1		
	Blade right 2			
	Blade left 1			
	Blade left 2			
	Frame rotation			
	ESC		back	
	ChanlDef		No function	
	FactSett		For factory only	
	UseManage	Limit	LimitTime	No function
			limitCont	No function
DefConfig		YES	Return to default	
		NO	back	
FacConfig		SAVE	Save and back	
		EPRT	for factory only	
		ESC	back	
	ESC	back		
UNLOCK	Verify1:	0-255	need password	
	Verify2:			
		KEY	need password	

			ESC	back	
MANUAL	LAMP REST		ALL MOTER	All step motor(do not adjust it)	
			XY MOTER	Pan/Tilt step motor adjust(do not adjust it)	
			PART MOTER	Other step motor(except Pan/Tilt)	
			YES	The chosen step motor reset	
			ESC	Back	
	TEST RUN	AUTO			Auto
		SOUND			Sound
			ESC		Back
	SMULATE DMX	Pan:		0-255	Control Channel on display
		Pan Fine:			
		Tilt:			
		Tilt Fine:			
		PT Speed:			
		Special Fun:			
		Colour:			
		Colour2:			
		Colour3:			
		Cyan Colour:			
		Magenta Colour:			
		Yellow Colour:			
		Static Gobo:			
		Rot Gobo:			
		Gobo Rot:			
		Prism:			
		Prism Rot:			
Frost:					
Zoom:					
Zoom Fine					
Focus:					
Focus Fine:					
Strobe:					
Dimmer:					
		>	Value+1		
		<	Value-1		
		ESC	Back		
	ESC			Back	
SYSTEM INFO	DMX VALUE	CH00-CH37	0-255	DMX value number	
		CH00-CH41	0-255	DMX value number	

	LAMP REST	ALL MOTER	Right/Erro	For factory only
		XY MOTER		
		PART MOTER		
			ESC	Back
	OTHER INFO	Run Time:	0-9999	Machine runing hours
		Run Count:	0-9999	How many time of the Machine power on and off
		Residue T:	Most	Running time adjust(do not adjust)
		Residue C:	(do not adjust)	(do not adjust)
		Type:	xxxx	Mode No.
		Temp:	xxx	temperature
		Fan 1:	0-9999	Fan 1 speed
		Fan 2:	0-9999	Fan 2 speed
		DisVersion:	Vxxx	Version of display software
		XY Version:	Vxxx	Version of Pan/Tilt software
		M1 Version:	Vxxx	Software Version M1
M2 Version:		Vxxx	Software Version M2	
		ESC	Back	
ESC			Back	
DISPLAY SETTING	Light Set:		1-7Lev	Back Ground light level
	Light Off:		0n	Keep back ground light on
			1Min	Back light turn off after 1 min
			2Min	Back light turn off after 2 mins
			3Min	Back light turn off after 3 mins
	Menu Back:		Off	Turn off the menu and back
			1Min	Menu back after 1 min
			2Min	Menu back after 2 mins
			3Min	Menu back after 3 mins
	Light Flash:		Off	Back ground light flash function off
			0n	Back ground light flash function on
	Touch Cali:		Off	Touch screen calibration on
		0n	Touch screen calibration off	
		SAVE	Save and back	
		ESC	Back	
LAMP SETTING	Lamp Default:		Off	Lamp off
			On	Lamp on
	Manual Lamp:		Off	Lamp off by manual
			On	lamp on by manual
	LampTime		0000-9999	Lamp time
	LampState		Off	Lamp off
		On	Lamp on	

	Lamp Off:		10M	After 10 mins no signal come in, Lamp off
			Lifh	No signal come in , lamp keep lighting

13. DMX Channels

37 CH Mode	41 CH Mode	Function	DMX Value	Function description
1	1	Green+Blue	0–255	Linear Green+Blue
2	2	Magenta	0–255	Linear Magenta
3	3	Yellow	0–255	Linear Yellow
4	4	CTO	0–255	Linear CTO movement
5	5	Color wheel	0–7	white
			8–15	white+colour1
			16–23	colour1
			24–31	colour1+colour2
			32–39	colour2
			40–47	Colour 2+colour 3
			48–55	colour3
			56–63	Colour 3+colour 4
			64–71	colour4
			72–79	Colour 4+ Colour5
			80–87	Colour5
			88–95	Colour5+Colour6
			96–103	Colour6
			104–111	Colour6+Colour7
			112–119	Colour7
6	6	Strobe	120–127	Colour7+white
			128–255	Run from slow to fast
			0–3	Strobe Close
			4–103	Strobe from slow to fast
			104–107	Strobe Open
			108–207	Random Strobe from slow to fast
			208–212	Strobe Open
213–251	Random Strobe from slow to fast			
252–255	Strobe Open			
7	7	Dimming	0–255	Linear dimming
8	8	dimmer fine	0–255	No function
9	9	Aperture	0–131	Linear aperture from small to large
			132–171	Iris pulsation from slow to fast

				speed
			172-211	Iris pulsation from slow to fast speed with fast opening
			212-251	Iris pulsation from slow to fast speed with fast closing
			252-255	Maximum aperture
10	10	Fixed GOBO	0-7	No function
			8-15	GOBO 1
			16-23	GOBO 2
			24-31	GOBO 3
			32-39	GOBO 4
			40-47	GOBO 5
			48-55	GOBO 6
			56-63	GOBO 7
			64-71	GOBO 8
			72-113	Clockwise run from fast to slow
			114-117	Stop
			118-159	Anti-clockwise run from fast to slow
			160-171	GOBO 1 Shake
			172-183	GOBO 2 Shake
			184-195	GOBO 3 Shake
			196-207	GOBO 4 Shake
			208-119	GOBO 5 Shake
			220-231	GOBO 6 Shake
			232-243	GOBO 7 Shake
			244-255	GOBO 8 Shake
11	11	Rotate GOBO	0-18	No function
			19-37	GOBO 1
			38-56	GOBO 2
			57-74	GOBO 3
			75-92	GOBO 4
			93-111	GOBO 5
			112-129	GOBO 6
			130-150	GOBO 1 Shake
			151-171	GOBO 2 Shake
			172-192	GOBO 3 Shake
			193-213	GOBO 4 Shake
			214-234	GOBO 5 Shake
			235-255	GOBO 6 Shake
12	12	GOBO Rota	0-127	Index
			128-190	Rotation,Clockwise from fast to slow
			191-192	Stop
			193-255	Rotation,Anti-clockwise from

				slow to fast
13	13	GOBO Rota fine	0-255	No function
14	14	Prism	0-127	No function
			128-255	Prism
15	15	Prism Rota	0-127	Index
			128-190	Anti-clockwise run from fast to slow
			191-192	Stop
			193-255	Clockwise run from fast to slow
16	16	Frost	0	No function
			1-255	Linear frost
17	17	Blade up 1	0-255	Blade up 1
18	18	Blade up 2	0-255	Blade up 2
19	19	Blade down 1	0-255	Blade down 1
20	20	Blade down 2	0-255	Blade down 2
21	21	Blade right 1	0-255	Blade right 1
22	22	Blade right 2	0-255	Blade right 2
23	23	Blade left 1	0-255	Blade left 1
24	24	Blade left 2	0-255	Blade left 2
25	25	Frame rotation	0-255	Frame rotation
26	26	Focus	0-255	Focus
27	27	Focus fine	0-255	Focus fine
28	28	Zoom	0-255	Linear zoom
29	29	Autofocus	0-255	No function
30	30	Autofocus fine	0-255	No function
31	31	Pan rotation	0-255	0~540°
32	32	Pan Fine	0-255	Pan Fine
33	33	Tilt rotation	0-255	0~270°
34	34	Tilt Fine	0-255	Tilt Fine
35	35	Tilt Fine	0-255	No function
36	36	Reset	0-25	No function
			26-76	small step motor Reset
			77-127	Pan/Tilt Reset
			128-255	System reset
37	37	LED Lamp	0-25	No function
*	38	P/T speed	0-255	P/T ,Adjust speed
*	39	Color wheel speed	0-255	No function
*	40	Speed of light wheel	0-255	No function
*	41	GOBO wheel speed	0-255	No function

14. ROUTINE MAINTENANCE

Cleaning and maintenance



Warning:

- 1、 Turn off the power before opening any cover.
- 2、 Dust or floats can be blown gently with a vacuum cleaner or a pressure blow machine.
- 3、 In order to ensure the projector could work normally.It should be kept clean always.It is recommended that the fans and ventilation in let should be cleaned every 15 days.The lens and dichroic colour filters should also be regulary cleaned to maintain an optimum light output.Do not use any type of solvent on dichroic colour filters.It will damage the projector.
- 4、 Suggestion:The continue usage of the light don't exceed 4 hours.Or it will shorter the usage of the lamp.Please use the alternative operation to solve this problems.
- 5、 Please disconnect the power supply when begin to maintenaceor takedown the light.Please let the parts cool down 10 minute at least then begin to install. If need ro replace the lamp,please wait 10 minute again at least to let the lamp cool down completely or which maybe burned down.
- 6、 Please inspect the lens or other moving parts timing and keep them clear and static.If find anything damaged or losseness,must change a lamp or fix the lamp in order to avoid the accident.
- 7、 The light use the strong cool system.It is easy for the dirty to be collected.Please do clear the hot-ask one time two week at least.
- 8、 After you use the light,please check the intake place whether there are some wastepaper,please clean it up,or the windmill will break down and causing fire.